

Sliding clips with countersunk holes

Versions:

For different seam heights:	25 mm (standard)	Article-No.: HA-8360
	28 mm	Article-No.: HA-8360-28
	30 mm	Article-No.: HA-8360-30
	32 mm	Article-No.: HA-8360-32
	38 mm	Article-No.: HA-8360-38

Material:	Stainless steel V2A	Material-No. 1.4301
	Stainless steel V4A	AISI: 304 Material-No. 1.4401 as special design available

Thickness:	0,4 mm 0,5 mm as special design possible
-------------------	-----------------------------------------------------------

Illustration:

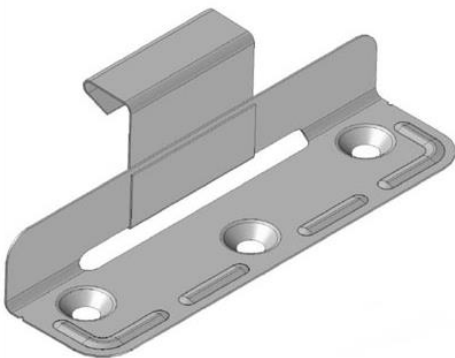

Description:

Sliding clips for angle- and double standing seam

Upper and bottom part are pre-assembled.
Attach on the pre-profiled standing seam.
Bottom part with special holes for countersunk screws.

Measurements and material thickness are according to the expert regulations of the German plumping crafts.

Due to a longer sliding range of 55 mm suitable for the following sheet lengths till:

12 meters	for titanium-zinc
14 meters	for copper
16 meters	for stainless steel
16 meters	for zinc-coated steel sheet
11 meters	for aluminium

Packing unit: 500 pcs. or 400 pcs. (Art.-Nr. HA-8360-38)

One of many features is that the clips are easy to assemble. The bottom part also comes with beading and rounded edges. Based on this innovation the clips barely bend up. It is most important to mount the clips absolutely accurate! It is indispensable to rework protruding nails or screws to avoid the damaging the roof layer. Due to the special shaping of the upper part, a slight clamp-effect is achieved. The result is that the attached clips will not slip down during the assembly process.

Please note our large product range around metal roofs: snow retention systems, step brackets, solar holders and our program about clips. Further informations you will find on our homepage.